

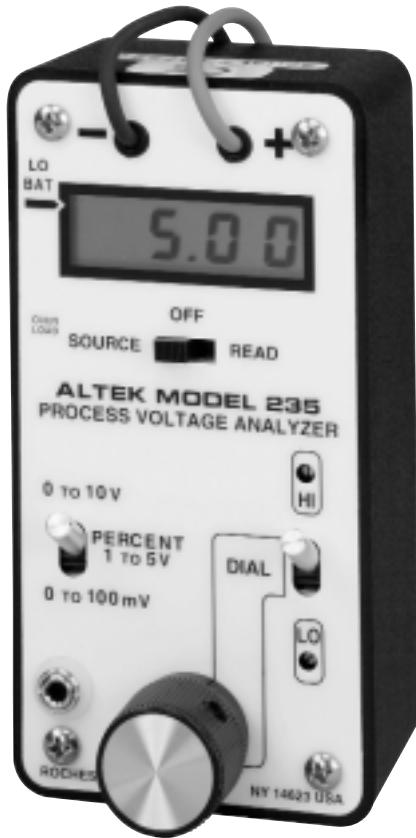

Process Voltage Analyzer Model 235



- Calibrate voltage instruments
Simulate Inputs
Check Outputs
- Three ranges with 0.05% accuracy
0.0 to 199.9 Millivolts
0.00 to 19.99 Volts
-25.0 to 199.9% of 1 to 5 Volts
- Calibrate live voltage input receivers
No need to disconnect loop
- "Quik-Chek[®]" switch
Set HI & LO outputs to match your Span & Zero
Instantly switch between HI & LO outputs
- Automatic overload protection
Withstands 120V AC or DC without fuses

General description

Calibrate and check out all your DC voltage instrumentation with Altek's Model 235 Process Voltage Analyzer. Source from millivolts to 20 VDC and measure your process voltage signals with this single pocket sized instrument

Display your readings with 0.1% resolution from 0.0 to 199.9 millivolts, 0.00 to 19.99 Volts or from -25.0 to 199.9% of the 1 to 5 Volt signal. Accuracy is $\pm 0.05\%$ of span.

Source voltage

Built-in batteries calibrate high or low impedance voltage or millivolt instruments. Accuracy is maintained to devices requiring up to 30mA. Three nine volt alkaline batteries provide 100 hours of use into high impedance loads. An optional AC adapter plugs in for continuous bench use.

Instantly recall three output voltages

User adjustable Quik-Chek switch provides instant HI and LO settings in source mode. DIAL position selects a continuously adjustable potentiometer. Full 10 turns with high resolution allows fast, easy setting to any exact value.

Calibrate live circuits

Automatically calibrate live circuits without disconnecting wires. Circuit sinks up to 20mA to clamp test voltage in all ranges. 1 to 5 Volt devices in live 4 to 20mA loops can be calibrated without any effect on the other instruments in the loop.

Measure voltages

Precisely measure positive and negative voltages in the 100mV and 10V ranges. 0 to 100% is displayed in the 1 to 5 Volt range for checkout of process control instruments. High input resistance (>2 Megohms) minimizes loading effect on signals. Special protective circuitry withstands misconnection to 120V AC in any mode without fuses.

Display digits are 0.35" (9mm) high for readability from across the room. Non-glare liquid crystal display is readable in any light...even in direct sunlight. The digital measuring circuit is independent and measures the actual input or output.

The Altek Model 235 is rugged, yet lightweight and pocket sized. Backed by a three year warranty, the Model 235 is toolbox tough. Latest LSI circuitry and wide temperature range components make the Model 235 ideal for use in the field, control room and shop.

Benchtop accuracy in a toolbox calibrator assures fast, precise setting of trips, recorders, controllers, loggers, computers and analysis instruments. Altek brings you the handy Model 235 Process Voltage Analyzer at a cost low enough for every check-out and maintenance person.

Operating instructions

Calibrate voltage inputs

Disconnect one or both input wires from the device to be check or calibrated. Attach the red (+) lead of the Model 235 to the plus input of the device to be calibrated, connect the black (-) lead to the minus terminal. Select the desired range and turn the SOURCE/OFF/READ mode selector switch to the SOURCE position. Actual voltage sent to the receiving device is shown on the LCD.

Output voltage is continuously adjustable with the QUIK-CHEK switch in the DIAL position. The source voltage can be set to any exact value from 0 to 200mV, 0 to 20V or -25 to 125% of 1 to 5V. HI and LO values are user adjustable and can be instantly selected by the QUIK-CHEK switch.

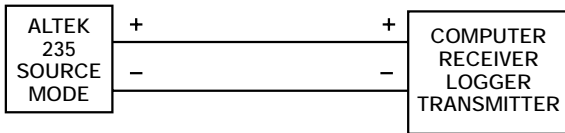

Measure voltage outputs

Place the leads of the MODEL 235 across the voltage signal to be measured. Place the MODE Switch in the READ position and select the range to be measured. Choose the 100mV position for signals from -199.9mV to +199.9mV. Signals from -19.99V to +19.99V can be measured with the 10V range. 1 to 5V signals can be displayed in units of 0 to 100% to monitor live process signals. When measuring voltages from high impedance sources, the source resistance effect is 0.1% per 2000 Ohms. All ranges are fully protected to 120V AC against misconnection.

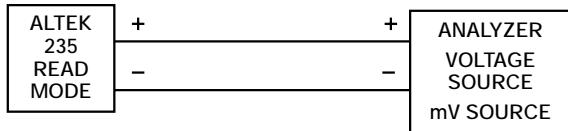

Check 1 to 5V inputs in live loop

Any 1 to 5V device in a 4 to 20mA loop can be calibrated without breaking the loop or turning off the signal current. Clip the red lead to the positive input terminal and the black lead to the negative of the device to be checked or calibrated. It is not necessary to disconnect any associated 250 Ohm resistor. Make certain that changing the signal input will not disturb the process or cause unexpected alarms when checking on-line instruments.

It is important to remember the Model 235 drives only the device to which it is connected. It has no effect on other devices in the 4 to 20mA loop.

Set the RANGE switch to the 1 to 5 Volt range and the MODE switch to SOURCE. the LCD will display 0 to 100% corresponding to the 1 to 5 Volts required by the device being calibrated. The voltage is set to any exact value by the 10 turn dial. Adjust HI and LO trimmers to desired values for fastest repetitive calibration through the QUIK-CHEK switch.

Additionally, SINK MODE will clamp the selected value in the 100mV and 10V Ranges to the maximum sink current of 20mA. For example, receivers requiring 0.25 to 1.25V may be calibrated in the 10 Volt range. Connect the Model 235 across the 62.5 Ohm resistor and set the LO and HI QUIK-CHEKS for 0.25 and 1.25V.

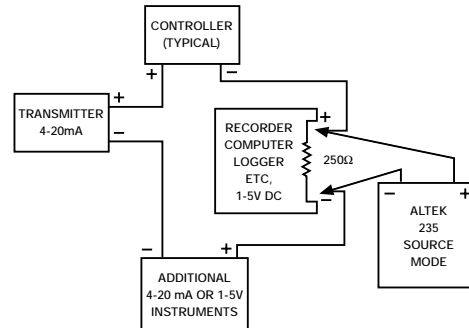

Specifications

Unless otherwise Indicated, specifications are in % of Span @ 23° C

Accuracy: $\pm(0.05\%$ of Span + 1 Least Significant Digit)

Display: Liquid Crystal; 3 1/2 digit, 0.35" (9.0mm) high

Negative voltages: Measured on 100mV and 10V ranges

"Quik-Chek" Factory preset at 0% and 100% (1 and 5V)

ADJUSTMENT RANGE LO HI

20 Volts 0.10V to +1.50V 0.75V to 11.00V

Percent 1 to 5 V -25.0% to +12.0% -10.0% to 199.9%

200 Millivolts -2.0mV to +25.0mV 10mV to 199.9 mV

Batteries: 3 x 9 Volt alkaline are included

Battery life: Nominal 100 Hours, Sourcing into high impedance loads; nominal 20 Hours at 20mA Drain. Batteries should be removed when storing the unit >3 months.

Source current: 30mA Maximum

Sink current: 20mA Maximum

Output impedance: <0.3 Ohm

Input resistance (Read mode): >2 Megohms

Source resistance effect (Read mode): 0.1% error per 2000 Ohms

Overload protection: Protected to 120 Volts AC or DC

Overload indicator: Lamp indicates high current or misconnection

Short circuit duration: Continuous

Low voltage indicator: LO BAT arrow turns on at 18 Volts

(approximately 10 operating hours remain)

Temperature effect: $\pm 0.01\%/^{\circ}\text{C}$ (Based on 23°C $\pm 23^{\circ}\text{C}$ Recommended Range)

Recommended temperature range: 32 to 122°F (0 to 50°C)

Operating temperature range: -5 to +140 °F (- 20 to + 60 °C)

Storage temperature range: -22 to +175°F (-30 to +80°C)

Relative humidity: 10 to 90%, non-condensing

Warm up time: 3 seconds to rated accuracy

Overall size: 2 1/2 x 2 5/8 x 5 1/8 inches (63.5 x 66.7 x 130 mm)

Weight: 12.5 oz (0.35 kg)

AC Adaptors: optional; 120 or 240V, 50/60 Hz

Carrying case: optional, zippered with belt loop

Warranty

Altek products are warranted to be free from defects in material and workmanship (excluding fuses, batteries and leads) for a period of three years from the date of shipment. Warranty repairs can be obtained by returning the equipment prepaid to our factory. Products will be replaced, repaired, or adjusted at our option. *Altek gives no other warranties, including any implied warranty of fitness for a particular purpose.* Also, Altek shall not be liable for any special, indirect, incidental or consequential damages or losses arising from the sale or use of its products.

Altek Industries, Inc.

PO Box 1106, Everett, WA 98206

1520 75th Street SW, Everett, WA 98203

For more information:

U.S.A. (800) 322-5835

Fax (800) 265-6340

Service fax (425) 446-6331

E-mail: sales@altekcalibrators.com

Web: www.altekcalibrators.com

PN 1886496 Rev A April 2002

©2002 Altek Industries, Inc. Specifications subject to change without notice.

All rights reserved. Printed in U.S.A.