

MULTIFUNCTION LOOP CALIBRATOR MODEL 934

- **LABORATORY ACCURATE**
±(0.012% of Reading + 0.008% of Full Scale Reading)
Accurate to ±0.004 mA from 4 to 20 mA
- **HIGH RESOLUTION FIVE DIGIT DISPLAYS**
Source up to 24.000 mA, 20.000 V or 999.90 mV
Read up to 52.000 mA, 99.990 V or 999.90 mV
- **USER SETTABLE "QUIK-CHEKS®"**
Set any Span & Zero
- **DUAL LIQUID CRYSTAL DISPLAY**
Simultaneous Source and Read
- **SCALEABLE DISPLAY**
Set in engineering units
- **SPEED SENSITIVE DIGIPOT**
Fast setting to any desired value
- **"AUTO-CHEK™" OUTPUT**
Automatically switches output in 2, 3, 5 or 10 steps
- **ISOLATED SOURCE AND READ**
Isolated to 500VDC
Fuseless protection to 120 V AC/DC
- **CE OPTION AVAILABLE**



GENERAL INFORMATION

Simultaneously source and read any combination of process milliamp and voltage signals. Altek's Model 934 combines all the functions of a milliamp and a voltage calibrator! Output and input signals are continuously displayed. The top half of the display indicates the output setting while the lower half shows the signal being measured.

Calibrate state-of-the-art equipment such as smart transmitters and indicators with your Model 934. Full 5 digit resolution lets you check any brand of process control equipment. Your calibrations are correct to better than 0.02% of reading. This is several times more accurate than 3½ to 5½ digit multimeters reading millimaps.

Use the scaleable display to match the readings on the Model 934 to that of the equipment being calibrated. For example, if your 4 to 20 mA recorder scale is 0.0 to 300.0 gallons/hour you can set the 934 to display 0.0 for 4 mA and 300.0 for 20 mA. No need to use your calculator or look-up tables to come up with the correct milliamp values.

Six "AA" alkaline batteries source more than 20 hours continuous at 20 mA . . . more than 3 months of typical use. From the time the low battery indicator first comes on you have hours of power remaining to get you through a shift without interruption. The 934 comes configured to automatically power down after 30 minutes of inactivity to save battery life.

Calibrate loop converters and isolators by simultaneously providing the input signal and measuring the output of the converter or isolator. Internal optoisolators withstand up to 500 VDC between the source and read leads. Calibrate and checkout all your process milliamp and voltage instruments with the "benchtop accurate" Model 934.

MILLIAMP CALIBRATION

Use at every point in your 4 to 20 milliamp loop. Source milliamps directly into your receivers with loop loads up to 1200 Ohms. Simulate 2-Wire Transmitters for checkout of field wiring and total loop testing. Power and measure 2-Wire or 4-Wire transmitters on the bench before installation. Read Transmitter & Controller outputs up to 52.00 mA. Display directly in milliamps, percent of 4 to 20 mA, percent of DP Flow or engineering units to match the scale of your process.

VOLTAGE CALIBRATION

Calibrate and checkout all your DC Voltage instrumentation. Source up to 999.90 millivolts to simulate sensors and up to 20.000 Volts to check your process signal inputs. Measure voltages from -99.990 to +99.990 VDC to check your power supplies and the outputs from any process voltage equipment.

Calibrate any 1 to 5 Volt device in a live 4 to 20 milliamp loop without disconnecting any wires. The Model 934 will automatically source or sink 0 to >16 milliamps to clamp the test voltage in all source ranges. Output impedance is less than 0.2 Ohm to let you calibrate voltage instruments in milliamp loops without removing the input load resistors.

QUIK-CHEK & AUTO-CHEK

Instantly recall three output settings in each range with the handy QUIK-CHEK switch. All output settings are remembered for each function, even with the power off.

Use the AUTO-CHEK to automatically switch the Model 934's output from Zero to Span in 2, 3, 5 or 10 equal steps at intervals of 5 to 900 seconds. Connect behind the panel and do your calibration from the front...or simulate your 2-Wire transmitter and calibrate every device in the loop.

ALTEK INDUSTRIES CORP
A TRANSMATION COMPANY

35 Vantage Point Drive Rochester, New York 14624 U.S.A.

(716) 349-3500 • Fax: (716) 349-3510

E-Mail: alteksales@altekcalibrators.com • <http://www.altekcalibrators.com>

OPERATING INSTRUCTIONS

SOURCE FUNCTIONS

The SOURCE functions generate or control the desired signal. Multiple scales are available for each function.

CALIBRATE MILLIAMP INPUTS

mA, mA %, mA ENG. UNIT, mA % DP FLOW

Choose this function to provide an output from 0.000 to 24.000 milliamps. The compliance voltage is a nominal 24 VDC to provide the driving power to your milliamp receivers.

Output current is continuously adjustable with the "QUIK-CHEK" switch in the SET position. Zero & Span (or any other values) are available by using the LO and HI "QUIK-CHEKs".

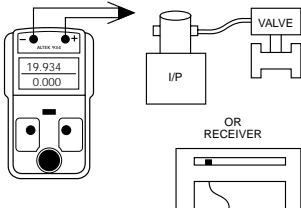

POWER & MEASURE 2-WIRE TRANSMITTERS

PWR XMTR mA, PWR XMTR %, PWR XMTR ENG. UNIT, PWR XMTR, % DP FLOW

Choose this function to simultaneously supply power to a 2-Wire transmitter while displaying the 4-20 mA output of the transmitter.

The Model 934 supplies a nominal 24 Volts DC at 24 mA to the 2-Wire transmitter. The current passed by the transmitter will be accurately displayed by the 934

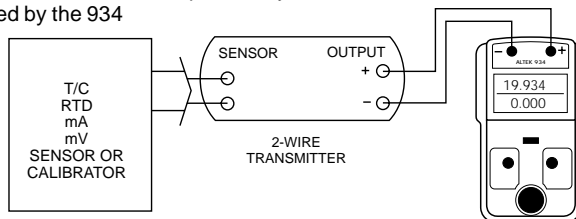

SIMULATE 2-WIRE TRANSMITTERS

2-WIRE SIM mA, 2-WIRE SIM %, 2-WIRE SIM ENG. UNIT, 2-WIRE SIM % DP FLOW

Choose this function to simulate a 2-Wire Transmitter output from 3.000 to 24.000 milliamps. Operates in loops with power supplies from 3 to 45 VDC.

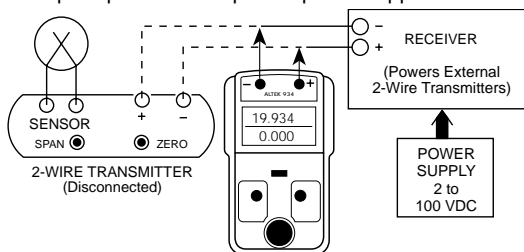

CHECK 1-5 VOLT INPUTS WITHOUT DISCONNECTING WIRES

**V, V ENG. UNIT
mV, mV ENG. UNIT**

Choose this function to calibrate any 1 to 5 Volt device in a 4 to 20 mA. loop without breaking the loop or turning off the signal current.

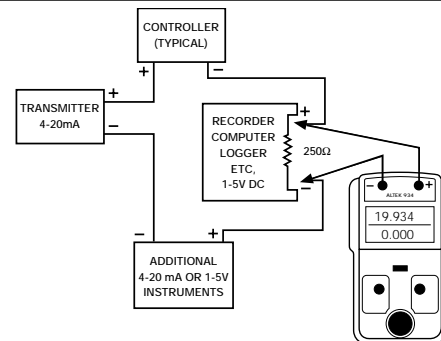

CALIBRATE VOLTAGE INPUTS

**V, V ENG. UNIT
mV, mV ENG. UNIT**

Choose this function to provide an output from 0.00 mV to 999.90 mV and from 0.000 to 20.000 VDC. Source current is a maximum of 30 mA to provide the driving power to your voltage receivers.

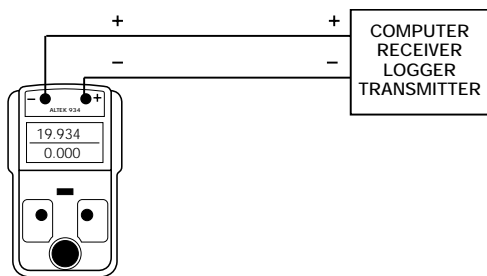

CALIBRATING LOOP CONVERTERS & ISOLATORS

Calibrate your 4-20 milliamp and voltage loop converters and isolators without any additional test equipment or power supplies.

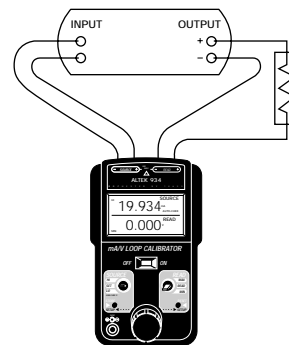

READ FUNCTIONS

The READ functions measures the desired signal. Multiple scales are available for each function.

READ MILLIAMP OUTPUTS

mA, mA %, mA ENG. UNIT, mA % DP FLOW

Choose this function to measure from -52.00 to +52.00 milliamps. For checking controller output and process loop currents the input is autoranged to higher resolution from -24.000 to +24.000 milliamps.

Display the present reading. Maximum or Minimum by moving the toggle switch from READ to MAX or MIN. If the Model 934 is connected in the wrong polarity, the display will indicate negative current. Simply reverse the leads for correct indication.

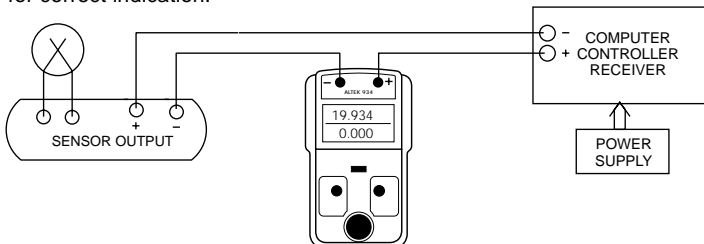

READ VOLTAGE OUTPUTS

V, mV, V ENG. UNIT

Choose this function to measure from -99.990 to + 99.990 Volts. For checking sensor outputs and other low level signals the input is autoranged to display from -999.90 to +999.90 millivolts.

Loop power supplies, signal voltages at receivers, batteries, transmitter voltage drops and any other voltages may be measured. Signals above or below those available for the currently selected range will be indicated by OVER and UNDER on the display.

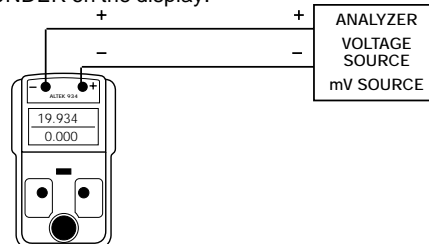

RANGES

MILLIAMPS - mA

Choose mA to display directly in milliamps. Display in SOURCE and READ functions from 0.000 to 24.000 mA. In READ you can also measure up to 52.00 mA.

VOLTAGE - V

Choose V to display directly in DC Volts. Use for 0 to 1 Volt, 1 to 5 Volt or 0 to 10 Volt signals. SOURCE from 0.000 to 20.000 VDC. In READ the 934 autoranges between -999.90 to +999.90 millivolts and -99.990 to +99.990 VDC.

MILLIVOLTS - mV

Choose mV to display directly in millivolts DC. Use 0 to 100 millivolts to check recorder or analyzer inputs. SOURCE from 0.00 to 999.90 mVDC. In READ the 934 autoranges between -999.90 to +999.90 millivolts and -99.990 to +99.990 VDC.

ENGINEERING UNITS - ENG. UNIT

Choose ENG. UNIT to match the display of the instrument being calibrated. Any span in mA, mV or V in Source or Read can be scaled to display a maximum of between -90000 to +90000 with zero to three digits to the right of the decimal point.

PERCENT OF 4 - 20 MILLIAMPS - mA %

Choose mA % to display in percent of span for 4 - 20 mA loops. Use with chart recorders or current trips that display in %.

0.00%	4.000 mA
25.00%	8.000 mA
50.00%	12.000 mA
75.00%	16.000 mA
100.00%	20.000 mA

$$\text{Percent} = (\text{mA}-4)/0.16 \quad \text{mA} = (\text{Percent}/6.25)+4$$

PERCENT DIFFERENTIAL PRESSURE - % DP

Choose % DP to display in percent of the square law for 4 - 20 mA loops. Also use to calibrate square root extractors and other square law mA inputs.

0.0%	4.000 mA
25.0%	5.000 mA
50.0%	8.000 mA
75.0%	13.000 mA
100.0%	20.000 mA

$$\%DP = (\sqrt{\text{mA}-4})\times 25 \quad \text{mA} = (\%DP/25)^2 + 4$$

SPECIFICATIONS

MODEL 934 RANGES AND ACCURACIES

Source mA & Simulate 2-Wire Transmitter ¹					
mA	LOW	HIGH	ACROSS ²	LOW ²	HIGH ²
OUTPUT	LIMIT	LIMIT	100 OHM	LIMIT	LIMIT
24.000mA	23.995	24.005	(2.4000V	2.3995	2.4005)
20.000	19.996	20.004	(2.0000	1.9996	2.0004)
12.000	11.997	12.003	(1.2000	1.1997	1.2003)
4.000	3.998	4.002	(0.4000	0.3998	0.4002)
0.000	-0.002	0.002	(0.0000	-0.0002	0.0002)

Source % 4-20 mA & Simulate 2-Wire Transmitter ¹					
%4-20mA	LOW	HIGH	ACROSS ²	LOW ²	HIGH ²
OUTPUT	LIMIT	LIMIT	100 OHM	LIMIT	LIMIT
125.00%	23.995	24.005	(2.4000V	2.3995	2.4005)
100.00	19.996	20.004	(2.0000	1.9996	2.0004)
50.00	11.997	12.003	(1.2000	1.1997	1.2003)
0.00	3.998	4.002	(0.4000	0.3998	0.4002)
-25.00	-0.002	0.002	(0.0000	-0.0002	0.0002)

Source % DP Flow & Simulate 2-Wire Transmitter					
%FLOW	LOW	HIGH	ACROSS ²	LOW ²	HIGH ²
OUTPUT	LIMIT	LIMIT	100 OHM	LIMIT	LIMIT
100.00%DP	19.996	20.004	(2.0000V	1.9996	2.0004)
50.00	7.997	8.003	(0.8000	0.7997	0.8003)
0.00	3.998	4.002	(0.4000	0.3998	0.4002)

Power & Measure 2- Wire Transmitters					
mA	LOW	HIGH	ACROSS ²	LOW ²	HIGH ²
OUTPUT	LIMIT	LIMIT	100 OHM	LIMIT	LIMIT
24.000mA	23.995	24.005	(2.4000V	2.3995	2.4005)
20.000	19.996	20.004	(2.0000	1.9996	2.0004)
12.000	11.997	12.003	(1.2000	1.1997	1.2003)
4.000	3.998	4.002	(0.4000	0.3998	0.4002)
0.000	-0.002	0.002	(0.0000	-0.0002	0.0002)

Source Volts		
VOLT	LOW	HIGH
OUTPUT	LIMIT	LIMIT
20.000V	19.996	20.004
10.000	9.997	10.003
5.000	4.998	5.002
1.000	0.998	1.002
0.000	-0.002	0.002

Source Millivolts		
mV	LOW	HIGH
OUTPUT	LIMIT	LIMIT
999.90mV	999.70	1000.10
500.00	499.86	500.14
100.00	99.91	100.09
10.00	9.92	10.08
0.00	-0.08	0.08

Read Volts ³		
VOLT	LOW	HIGH
INPUT	LIMIT	LIMIT
99.990V	99.970	100.010
50.000	49.986	50.014
20.000	19.990	20.010
10.000	9.991	10.009
5.000	4.991	5.009
1.000	0.992	1.008

Read Millivolts ³		
mV	LOW	HIGH
INPUT	LIMIT	LIMIT
999.90mV	999.70	1000.10
500.00	499.86	500.14
100.00	99.91	100.09
10.00	9.92	10.08
0.00	-0.08	0.08

Read mA ³		
mA	LOW	HIGH
INPUT	LIMIT	LIMIT
52.00mA	51.99	52.01
30.00	29.99	30.01
24.000	23.995	24.005
20.000	19.996	20.004
12.000	11.997	12.003
4.000	3.998	4.002
0.000	-0.002	0.002

Read % 4-20 mA			
mA	%4-20mA	LOW	HIGH
INPUT	INPUT	LIMIT	LIMIT
24.000mA	125.00%	124.97	125.03
20.000	100.00	99.97	100.03
12.000	50.00	49.98	50.02
4.000	0.00	-0.02	0.02
0.000	-25.00	-25.01	-24.99

Read % DP Flow			
mA	%FLOW	LOW	HIGH
INPUT	INPUT	LIMIT	LIMIT
20.000mA	100.0%DP	100.0	100.0
8.000	50.0	50.0	50.0
4.000	0.0	-1.2	1.2

¹Simulate 2-Wire Transmitter range is from 3.000 to 24.000 mA

²100 Ohm resistor is used in the calibration procedure (See manual)

³LOW & HIGH LIMITS are identical for negative readings

THREE YEAR WARRANTY

Our equipment is guaranteed against defective material and workmanship (excluding batteries) for a period of three years from date of shipment. Claims under guarantee can be made by returning the equipment prepaid to our factory. The equipment will be replaced, repaired or adjusted at our option. The liability of Altek is restricted to that given under our guarantee No responsibility is accepted for damage, loss or other expense incurred through sale or use of our equipment. Under no condition shall Altek be liable for any special, incidental or consequential damage.

OTHER PRODUCTS

Altek designs and manufactures fast, accurate instruments for measurement, generation and simulation of virtually every process control signal. Consult our factory directly or contact your local stocking representative to order precise, low cost Calibrators for Milliamp, Voltage, Thermocouple, RTD, Frequency and pressure. Altek also produces calibrators for custom ranges and unique applications. Additional models and ranges are frequently added to the Altek instrument family to meet all of your critical calibration requirements. Altek products are produced in the USA.

SPECIFICATIONS

(Unless otherwise indicated, specifications are in $\pm\%$ of Reading @ 23°C)

GENERAL

ACCURACY: $\pm(0.012\%$ of Reading + 0.008% of Full Scale Reading)

Accuracy of scaled ranges (% of 4 to 20 mA, %DP Flow, Engineering units) are based on the value of the fundamental units (mA, V or mV).

WARM UP TIME: 10 seconds to specified accuracy, 2 minutes to maximum accuracy

TEMPERATURE EFFECT: $\pm 0.008\%/^{\circ}\text{C}$ based on $23^{\circ}\text{C} \pm 25^{\circ}\text{C}$

ISOLATION: 500 VDC between SOURCE & READ leads

Accuracies of the Source and Read ranges are independent. When Source and Read are connected together the accuracies are additive.

BATTERIES: Six "AA", (R6) batteries (Alkaline supplied and recommended)

BATTERY LIFE:

MILLIAMP SOURCE & 2-WIRE MODES: Nominal 33 hours at 12 mA, 20 hours at 20 mA into 250 Ohm load

OTHER FUNCTIONS: Nominal 40 hours

*AC ADAPTORS: Optional, nominal 115 or 230 VAC, 50/60 Hz

LOW BATTERY INDICATION: "BAT" indication on the display at approximately 4 hours left

OVERVOLTAGE PROTECTION: Protected to 120 Volts AC or DC in all ranges without fuses for 30 seconds

NOISE: ≤ 1 LSD at frequencies less than 10 Hz

NORMAL MODE REJECTION RATIO: 50 dB @ 50/60Hz

COMMON MODE REJECTION RATIO: Not applicable for battery operation. 120 dB @ 50/60 Hz with AC Adaptor

OPERATING TEMPERATURE RANGE:

-5 to $+130^{\circ}\text{F}$ (-20 to $+55^{\circ}\text{C}$)

STORAGE TEMPERATURE RANGE:

-13 to $+130^{\circ}\text{F}$ (-25 to $+55^{\circ}\text{C}$)

RELATIVE HUMIDITY: 10 to 90%, non-condensing for 24 hours from 0 to 35°C

OVERALL SIZE: $6\frac{11}{16} \times 4 \times 2\frac{15}{16}$ inches (170 x 102 x 75 mm)

WEIGHT: 1lb, 9oz (0.709 kg)

MILLIAMP SOURCE

RANGES:

0.000 to 24.000 mA

-25.00 to 125.00% of 4 to 20 mA

-50.0 to 111.8% of % DP Flow

Scaled Engineering Units (from -90000 to +90000 counts with up to three digits to the right of the decimal point)

ACCURACY: $\pm(0.012\%$ of Reading + 0.008% of 24.000 mA)

TYPICAL DRIVE CAPABILITY: 1200 Ohms @ 20.000 mA

POWER TO DRIVE RECEIVER: nominal 24 VDC

COMPLIANCE VOLTAGE:

0 to 285 Ohm load: 10V nominal

285 to 1200 Ohm load: 24V nominal

OVERLOAD PROTECTION: Current limited to 25 mA

POWER & MEASURE 2-WIRE TRANSMITTERS

RANGES & ACCURACY: Same as for MILLIAMP SOURCE above

OUTPUT CURRENT: up to 24.000 mA

TYPICAL DRIVE CAPABILITY: 1200 Ohms @ 20 mA

POWER TO EXTERNAL 2-WIRE TRANSMITTER:

nominal 24 VDC

OVERLOAD PROTECTION: Current limited to 25 mA

2-WIRE TRANSMITTER SIMULATOR

RANGES:

3.000 to 24.000 mA

-6.25 to 125.00% of 4 to 20 mA

-25.0 to 111.8% of % DP Flow

Scaled Engineering Units (from -90000 to +90000 counts with up to three digits to the right of the decimal point)

ACCURACY: $\pm(0.012\%$ of Reading + 0.008% of 24.000 mA)

LOOP VOLTAGE LIMITS:

Minimum, 3 VDC; Maximum 45 VDC

OVERLOAD PROTECTION: Current limited to 25 mA

Specifications subject to change without notice

MILLIAMP READ

RANGES:

-52.00 to -24.00¹

-24.000 to +24.000 mA²

24.00 to 52.00 mA¹

-25.00 to 125.00% of 4 to 20 mA

-50.0 to 111.8% of % DP Flow

Scaled Engineering Units (from -90000 to +90000 counts with up to three digits to the right of the decimal point)

¹**ACCURACY:** $\pm(0.012\%$ of Reading + 0.008% of 52.00 mA)

²**ACCURACY:** $\pm(0.012\%$ of Reading + 0.008% of 24.000 mA)

OVERLOAD PROTECTION: Current limited to less than 360 mA nominal

INPUT IMPEDANCE: 25 Ohms

VOLTAGE BURDEN:

0.2 V at 4 mA, 0.6 V at 20 mA, 1.4 V at 50 mA

MEASURING ACROSS A DIODE: Add $\pm 0.2\%$ to specification from 0 to 20 mA (Diode 1N 914 or equivalent)

VOLTAGE SOURCE

RANGES:

0.00 to 999.90 mVDC³

0.000 to 20.000 VDC⁴

Scaled Engineering Units (from -90000 to +90000 counts with up to three digits to the right of the decimal point)

³**ACCURACY:** $\pm(0.012\%$ of Reading + 0.008% of 999.90 mV)

⁴**ACCURACY:** $\pm(0.012\%$ of Reading + 0.008% of 20.000 V)

SOURCE CURRENT: > 24 mA

SINK CURRENT: > 16 mA from 1 to 5 VDC

OUTPUT IMPEDANCE: < 0.2 Ohm

LOAD RESISTANCE: > 3 Ohms

SHORT CIRCUIT DURATION: Infinite

OVERLOAD PROTECTION: Current limited to 50 mA nominal

VOLTAGE READ

RANGES:

-99.990 to -0.999 VDC⁵

-999.90 to 999.90 mVDC⁶

0.999 to 99.990 VDC⁵

Scaled Engineering Units (from -90000 to +90000 counts with up to three digits to the right of the decimal point)

⁵**ACCURACY:** $\pm(0.012\%$ of Reading + 0.008% of 99.900 V)

⁶**ACCURACY:** $\pm(0.012\%$ of Reading + 0.008% of 999.90 mV)

INPUT RESISTANCE: 2 Meg Ohm nominal

SOURCE RESISTANCE EFFECT: 0.01% error per 200 Ohms

MAXIMUM VOLTAGE LIMIT: 120 Volts DC to 100 Hz AC

ORDERING INFORMATION

Part No.

MODEL 934 MULTIFUNCTION LOOP CALIBRATOR

934

***MODEL 934-CE MULTIFUNCTION LOOP CALIBRATOR**

934-CE

Included with each Model 934 are:

Carrying Case (Part No. 09-3784)

Instruction Manual

NIST Traceable Certificate and Three Year Warranty

OPTIONAL ACCESSORIES

Part No.

AC ADAPTOR: 120 VAC, 50/60 Hz

9V-0120

AC ADAPTOR: 240 VAC, 50/60 Hz

9V-0240

*AC ADAPTORS NOT AVAILABLE FOR MODEL

934CE

AVAILABLE FROM: